

Characteristics

Mono-phase
Tailor-made height*
Compact design
High pressure Airstop
Preferred height 2.60m
Temperature difference 20-30°C

Models

COMPACT400-S (single standing)
COMPACT400-DS (double standing)
(X) = extra fan

Application

400-S up to 1.60m door width
400-DS up to 2.50m door width
Shops and supermarkets
Entrance of office buildings
Public buildings

Options

RAL colour
Stainless steel
Extension up to ceiling (dummy)
Heating (water, 60/40)
Heating (water, tailor-made adapted to your water temperature)

Steering

5-step/Frequency converter (STRM)

* Maximum outblow 2.60m

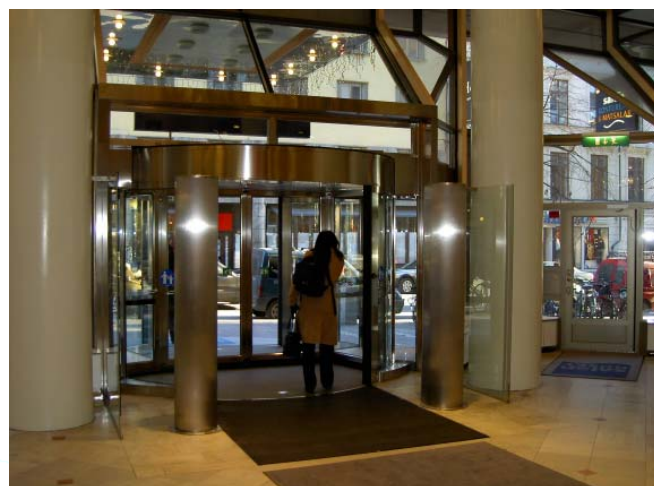

Masterveil Europe*

Brusselbaan 192, BE-9320 Erembodegem

Tel: +32 (0)53 60 78 90 | Fax: +32 (0)53 60 78 99 | Mail: office@deweerd.be

* Masterveil is a subsidiary of Deweerdt BVBA

Additional characteristics

- . Exclusive design in beautiful circular shape
- . Supply of electricity and water at top or bottom by choice
- . Outblow angle can be chosen
- . Special extension (hood) to connect to ceiling

Different parts:

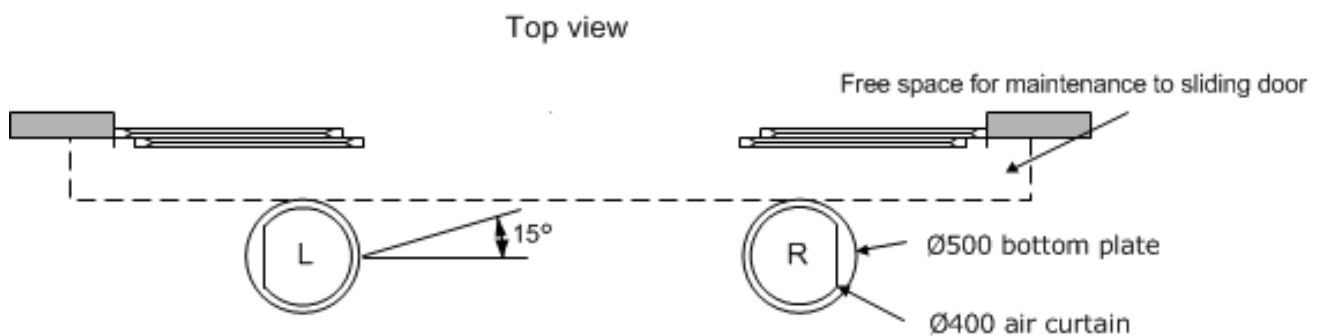
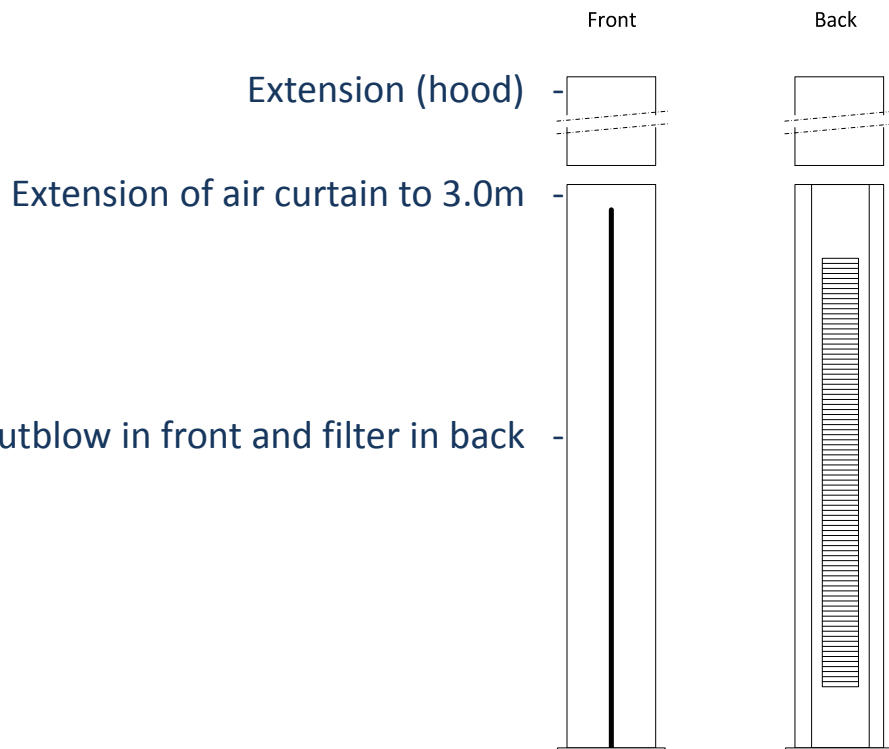

COMPACT400 has a fixed outblow angle of 15°. The special shaped bottom plate makes it possible to increase the angle up to 30°.

Masterveil Europe*

Brusselbaan 192, BE-9320 Erembodegem

Tel: +32 (0)53 60 78 90 | Fax: +32 (0)53 60 78 99 | Mail: office@deweerdtd.be

* Masterveil is a subsidiary of Deweerdt BVBA